

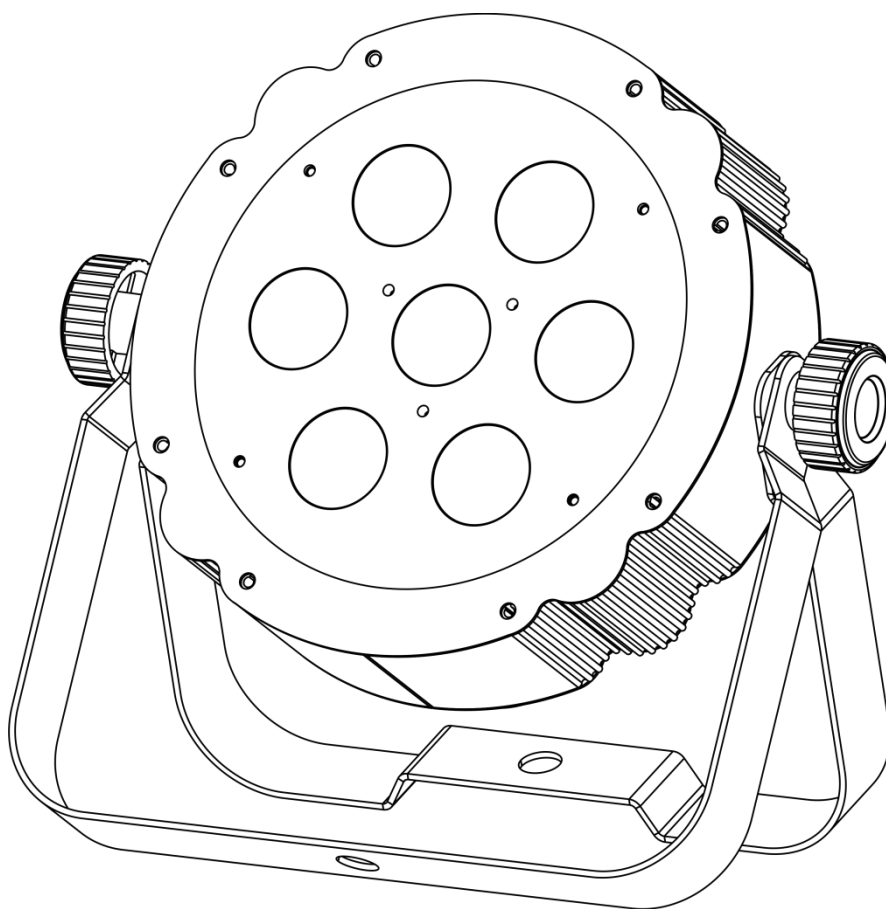

MANUAL



ENGLISH

Compact Par 7 Q4

V1

Ordercode: 42582

Table of contents

Warning	2
Safety Instructions	2
Operating Determinations	4
Rigging	4
Connection with the mains.....	5
Return Procedure	6
Claims.....	6
Description of the device	7
Frontside.....	7
Backside	8
Installation	8
Set Up and Operation	8
Control Modes.....	9
One Compact Par 7 Q4 (Auto Run Mode, Built-in programs and Static Color Mode)	9
One Compact Par 7 Q4 (Sound-controlled).....	9
Multiple Compact Pars 7 Q4 (Master/Slave control).....	9
Multiple Compact Pars 7 Q4 (DMX Control)	10
Fixture Linking.....	11
Data Cabling.....	11
Control Panel.....	12
Control Mode	12
DMX Addressing.....	12
Menu Overview.....	13
Main Menu Options.....	13
Auto Run Mode.....	14
Built-in Programs.....	14
DMX Addressing/ DMX configuration	14
Slave Mode.....	15
Static Color control.....	15
Sound control mode	15
Settings.....	15
Info.....	15
DMX Channels.....	16
4 channels.....	16
6 channels.....	16
11 channels.....	16
Maintenance	19
Replacing the Fuse.....	19
Troubleshooting	19
No Light.....	19
No Response to DMX.....	20
Product Specifications	21
Dimensions	22

Warning



**For your own safety, please read this user manual carefully
before your initial start-up!**



Unpacking Instructions

Immediately upon receiving this product, carefully unpack the carton and check the contents to ensure that all parts are present, and have been received in good condition. Notify the dealer immediately and retain packing material for inspection if any parts appear damaged from shipping or the carton itself shows signs of mishandling. Save the carton and all packing materials. In the event that a fixture must be returned to the factory, it is important that the fixture be returned in the original factory box and packing.

Your shipment includes:

- Showtec Compact Par 7 Q4
- IEC power cable (1,5 m)
- User manual

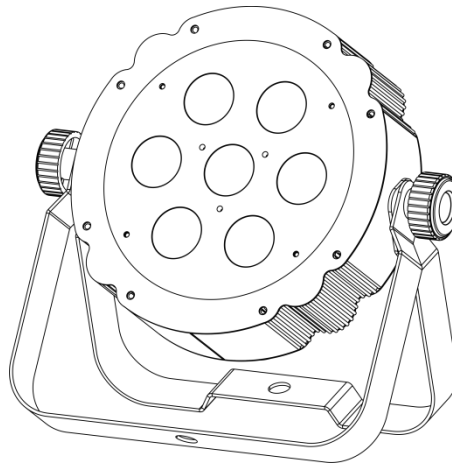

LED Expected Lifespan

LEDs gradually decline in brightness over time. HEAT is the dominant factor that leads to the acceleration of this decline. Packaged in clusters, LEDs exhibit higher operating temperatures than in ideal or singular optimum conditions. For this reason, when all color LEDs are used at their fullest intensity, life of the LEDs is significantly reduced. If improving the lifespan is of higher priority, place care in providing for lower operational temperatures. This may include climatic-environmental and the reduction of overall projection intensity.



CAUTION!

**Keep this device away from rain and moisture!
Unplug mains lead before opening the housing!**



Safety Instructions

Every person involved with the installation, operation and maintenance of this device has to:

- be qualified
- follow the instructions of this manual



**CAUTION! Be careful with your operations.
With a dangerous voltage you can suffer
a dangerous electric shock when touching the wires!**



Before the initial start-up, please make sure that there is no damage caused by transportation. Should there be any, consult your dealer and do not use the device.

To maintain perfect condition and to ensure a safe operation, it is absolutely necessary for the user to follow the safety instructions and warning notes contained in this manual.

Please consider that damages caused by manual modifications to the device are not subject to warranty.

This device contains no user-serviceable parts. Refer servicing to qualified technicians only.

IMPORTANT:

The manufacturer will not accept liability for any resulting damages caused by the non-observance of this manual or any unauthorized modification to the device.

- Never let the power cord come into contact with other cables! Handle the power cord and all connections with the mains with particular caution!
- Never remove warning or informative labels from the unit.
- Never use anything to cover the ground contact.
- Never lift the fixture holding it by the projector-head, as the mechanics may be damaged. Always hold the fixture by the transport handles.
- Never place any material over the lens.
- Never look directly into the light source.
- Never leave any cables lying around.
- Never loosen the screws of the rotating gobo otherwise you risk opening of the ball bearing.
- Do not insert objects into air vents.
- Do not connect this device to a dimmerpack.
- Do not switch the device on and off in short intervals, as this will reduce the device's life.
- Do not touch the device's housing bare-handed during its operation (housing becomes very hot). Allow the fixture to cool for at least 5 minutes before handling.
- Do not shake the device. Avoid brute force when installing or operating the device.
- Only use the device indoors, avoid contact with water or other liquids.
- Only operate the fixture after having checked if the housing is firmly closed and all screws are tightly fastened.
- Only operate the device after having familiarized with its functions.
- Avoid flames and do not put close to flammable liquids or gases.
- Always keep the case closed while operating.
- Always allow a free air space of at least 50 cm around the unit for ventilation.
- Always disconnect power from the mains, when device is not used or before cleaning! Only handle the power cord holding it by the plug. Never pull out the plug by tugging the power cord.
- Make sure that the device is not exposed to extreme heat, moisture or dust.
- Make sure that the available voltage is not higher than stated on the rear panel.
- Make sure that the power cord is never crimped or damaged. Check the device and the power cord from time to time.
- If the lens is obviously damaged, it has to be replaced.
- If device was dropped or struck, disconnect mains power supply immediately. Have a qualified engineer inspect for safety before operating.
- If the device has been exposed to drastic temperature fluctuation (e.g. after transportation), do not switch it on immediately. The arising condensation water might damage your device. Leave the device switched off until it has reached room temperature.
- If your Showtec device fails to work properly, discontinue the use immediately. Pack the unit securely (preferably in the original packing material), and return it to your Showtec dealer for service.
- For adult use only. The fixture must be installed beyond the reach of children. Never leave the unit running unattended.
- Never attempt to bypass the thermostatic switch or fuses.
- For replacement use fuses of same type and rating only.
- The user is responsible for correct positioning and operating of the Compact Par 7 Q4. The manufacturer will not accept liability for damages caused by the misuse or incorrect installation of this device.

- This device falls under protection class I. Therefore it is essential to connect the yellow/green conductor to earth.
- During the initial start-up some smoke or smell may arise. This is a normal process and does not necessarily mean that the device is defective.
- Repairs, servicing and electric connection must be carried out by a qualified technician.
- WARRANTY: Till one year after date of purchase.

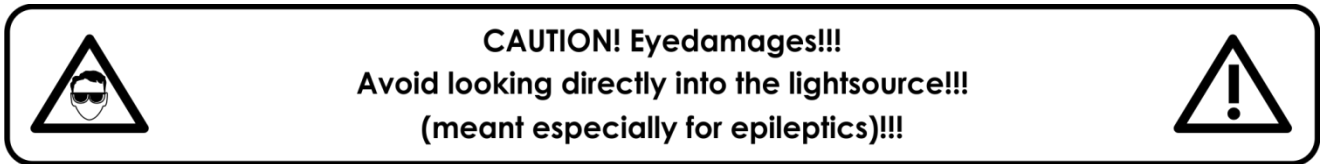

Operating Determinations

- This device is not designed for permanent operation. Consistent operation breaks will ensure that the device will serve you for a long time without defects.
- The minimum distance between light output and the illuminated surface must be bigger than 1 meter.
- The maximum ambient temperature $t_a = 40^\circ\text{C}$ must never be exceeded.
- The relative humidity must not exceed 50 % with an ambient temperature of 40°C .
- If this device is operated in any other way than the one described in this manual, the product may suffer damages and the warranty becomes void.
- Any other operation may lead to dangers like short-circuit, burns, electric shock, crash, etc.

You endanger your own safety and the safety of others!

Rigging

Please follow the European and national guidelines concerning rigging, trussing and all other safety issues.

Do not attempt the installation yourself !

Always let the installation be carried out by an authorized dealer !

Procedure:

- If the Compact Par is lowered from the ceiling or high joists, professional trussing systems have to be used.
- Use a clamp to mount the Compact Par, with the mounting bracket, to the trussing system.
- The Compact Par must never be fixed swinging freely in the room.
- The installation must always be secured with a safety attachment, e.g. an appropriate safety net or safety cable.
- When rigging, derigging or servicing the Compact Par, always make sure, that the area below the installation site is secured and that there are not any unauthorized people around.

Safety cable

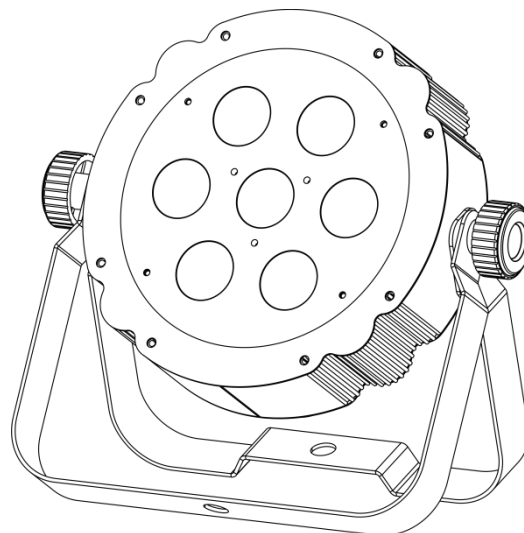
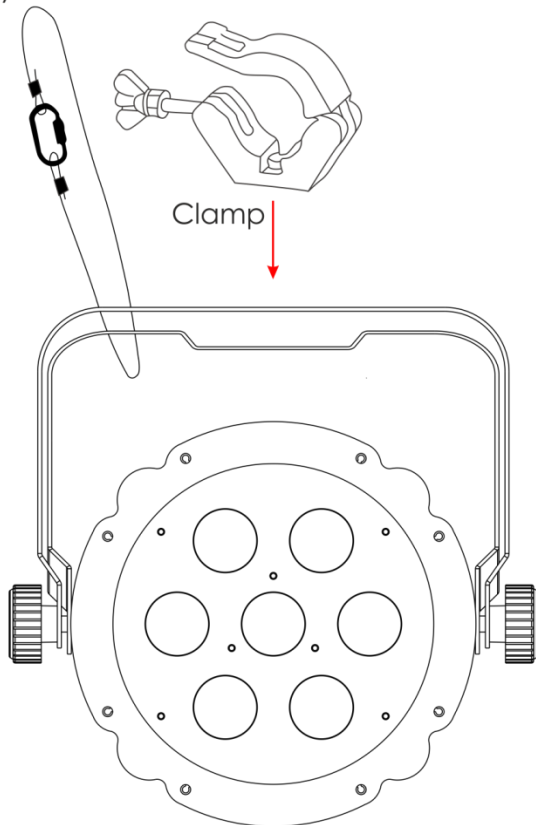

The Compact Par 7 Q4 can be placed on a flat stage floor or mounted to any kind of truss with a clamp.

Improper installation can cause serious injuries and/or damage of property!

Connection with the mains

Connect the device to the mains with the power-plug.

Always check if the right color cable is connected to the right place.

International	EU Cable	UK Cable	US Cable	Pin
L	BROWN	RED	YELLOW/COPPER	PHASE
N	BLUE	BLACK	SILVER	NEUTRAL
	YELLOW/GREEN	GREEN	GREEN	PROTECTIVE GROUND

Make sure that the device is always properly connected to the earth!

Improper installation can cause serious injuries and/or damage of property!





Return Procedure



Returned merchandise must be sent prepaid and in the original packing, call tags will not be issued. Package must be clearly labeled with a Return Authorization Number (RMA number). Products returned without an RMA number will be refused. Highlite will not accept the returned goods or any responsibility. Call Highlite 0031-455667723 or mail aftersales@highlite.com and request an RMA prior to shipping the fixture. Be prepared to provide the model number, serial number and a brief description of the cause for the return. Be sure to properly pack fixture, any shipping damage resulting from inadequate packaging is the customer's responsibility. Highlite reserves the right to use its own discretion to repair or replace product(s). As a suggestion, proper UPS packing or double-boxing is always a safe method to use.

Note: If you are given an RMA number, please include the following information on a piece of paper inside the box:

- 01) Your name
- 02) Your address
- 03) Your phone number
- 04) A brief description of the symptoms

Claims

The client has the obligation to check the delivered goods immediately upon delivery for any shortcomings and/or visible defects, or perform this check after our announcement that the goods are at their disposal. Damage incurred in shipping is the responsibility of the shipper; therefore the damage must be reported to the carrier upon receipt of merchandise.

It is the customer's responsibility to report and submit claims with the shipper in the event that a fixture is damaged due to shipping. Transportation damage has to be reported to us within one day after receipt of the delivery.

Any return shipment has to be made post-paid at all times. Return shipments must be accompanied with a letter defining the reason for return shipment. Non-prepaid return shipments will be refused, unless agreed otherwise in writing.

Complaints against us must be prepared in writing or sent by fax within 10 working days after receipt of the invoice. After this period complaints will not be handled anymore.

Complaints will only then be considered if the client has so far complied with all parts of the agreement, regardless of the agreement from which the obligation is resulting.

Description of the device

Features

The Compact Par 7 Q4 is a compact light effect with high output and great effects. It is the successor of the popular Compact par 7 Tri with 7x 4-in-1 RGBW LEDs.

- Flat stylisch design
- Double bracket
- Input voltage: 100-240V, 50/60Hz
- Drive Current: 330mA
- Refresh rate: 7,8 kHz
- Power consumption: 32W
- DMX channels: 4,6 or 11 channels
- 4-digit LED display for easy setup
- Light source: 7 x 4W RGBW LED
- Lux @2m: 2201
- Control modes: Built-in Programs, Auto, Sound-controlled, Static color, Master/Slave, DMX
- Control protocol: DMX-512
- Dimmer: 0-100%
- Strobe: 0-20Hz
- Beam Angle: 18°
- Protection rate: IP-20
- Housing: Aluminum and Iron
- Cooling: Aluminum heat sink
- Connections: IEC & 3-pin XLR IN & OUT
- Fuse: T1L/250V
- Dimensions: 272 x 92 x 260 mm (LxWxH)
- Weight: 2,14 kg

Frontside

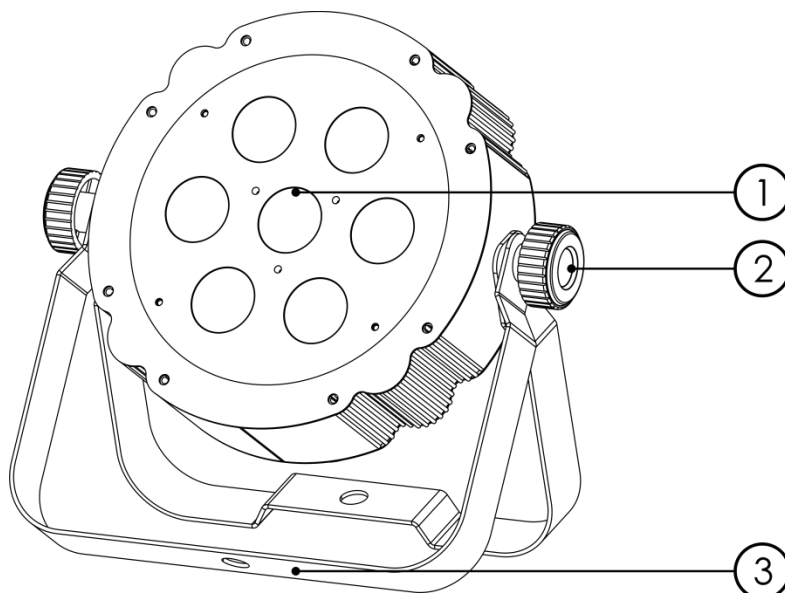

- 01) 7 x 4W RGBW LED
02) Adjustment screw
03) Mounting bracket

Fig. 01

Backside

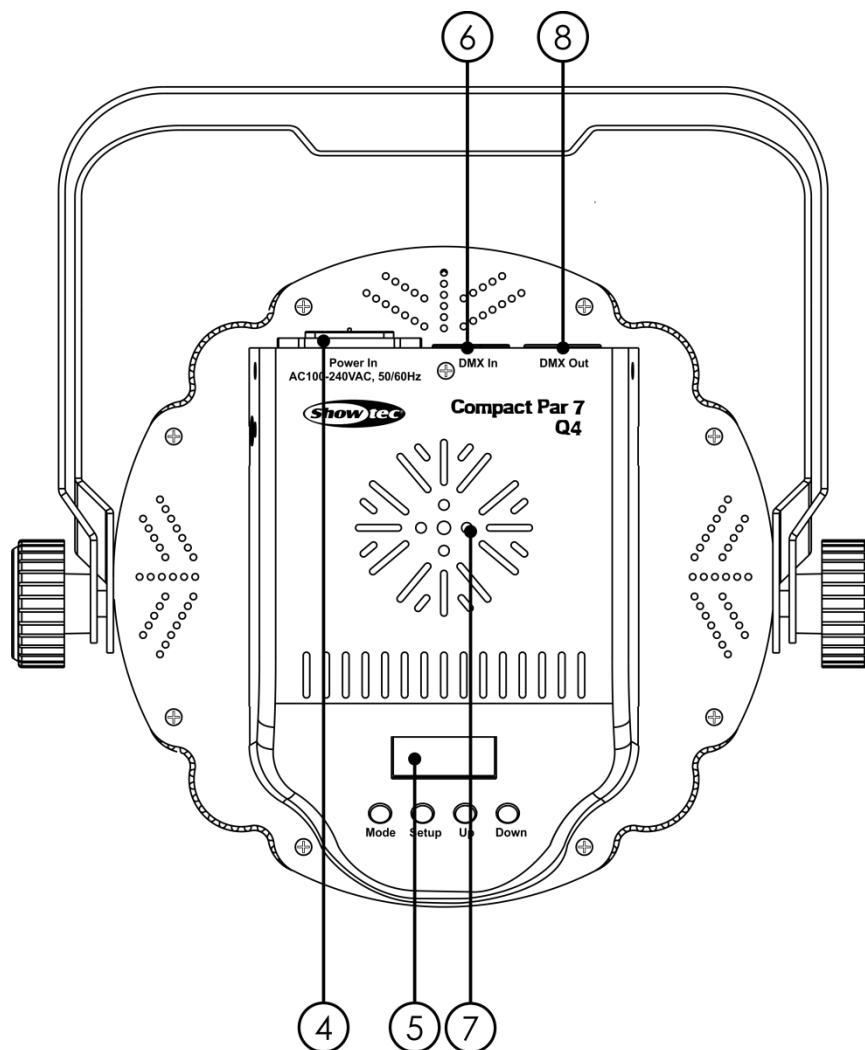

Fig. 02

- 04) IEC power connector
- 05) 4-digit LED display + menu buttons
- 06) 3-pin DMX signal connector IN
- 07) Cooling
- 08) 3-pin DMX signal connector OUT

Installation

Remove all packing materials from the Compact Par 7 Q4. Check if all foam and plastic padding is removed. Connect all cables.

Do not supply power before the whole system is set up and connected properly.

Always disconnect from electric mains power supply before cleaning or servicing.

Damages caused by non-observance are not subject to warranty.

Set Up and Operation

Follow the directions below, as they pertain to your preferred operation mode.

Before plugging the unit in, always make sure that the power supply matches the product specification voltage. Do not attempt to operate a 120V specification product on 230V power, or vice versa.

Connect the device to the main power supply.

Control Modes

There are 6 modes:

- Auto run
- Built-in programs
- Static Color
- Sound-controlled
- Master/slave
- DMX-512 (4CH, 6CH or 11CH)

One Compact Par 7 Q4 (Auto Run Mode, Built-in programs and Static Color Mode)

- 01) Fasten the effect light to a firm trussing. Leave at least 0,5 meter on all sides for air circulation.
- 02) Plug the end of the electric mains power cord into a proper electric power supply socket.
- 03) When the Compact Par is not connected with a DMX cable, it functions as a stand-alone device. Please see pages 14 and 15 for more information about Auto Run Mode, the Built-in programs and Static Color Mode.

One Compact Par 7 Q4 (Sound-controlled)

- 01) Fasten the effect light to a firm trussing. Leave at least 0,5 meter on all sides for air circulation.
- 02) Plug the end of the electric mains power cord into a proper electric power supply socket.
- 03) Turn on the music. If the device is set to sound-control, then the Compact Par will react to the beat of the music. Please see page 15 for more information about the sound-control options.

Multiple Compact Pars 7 Q4 (Master/Slave control)

- 01) Fasten the effect light onto firm trussing. Leave at least 0,5 meter on all sides for air circulation.
- 02) Always use a safety cable (ordercode 70140 / 70141).
- 03) Use a 3-p XLR cable to connect the Compact Par and other devices.

The pins:



1. Earth
2. Signal (-)
3. Signal (+)

- 04) Link the units as shown in Fig. 03, connect a DMX signal cable from the first unit's DMX "out" socket to the second unit's "in" socket. Repeat this process to link the second, third, and fourth units. You can use the same functions on the master device as described on pages 14 and 15 (Auto run, Built-in Programs, Static color). This means you can set your desired operation mode on the master device and all slave devices will react the same as the master device.

Multiple Compact Pars 7 Q4 (Master/Slave control)

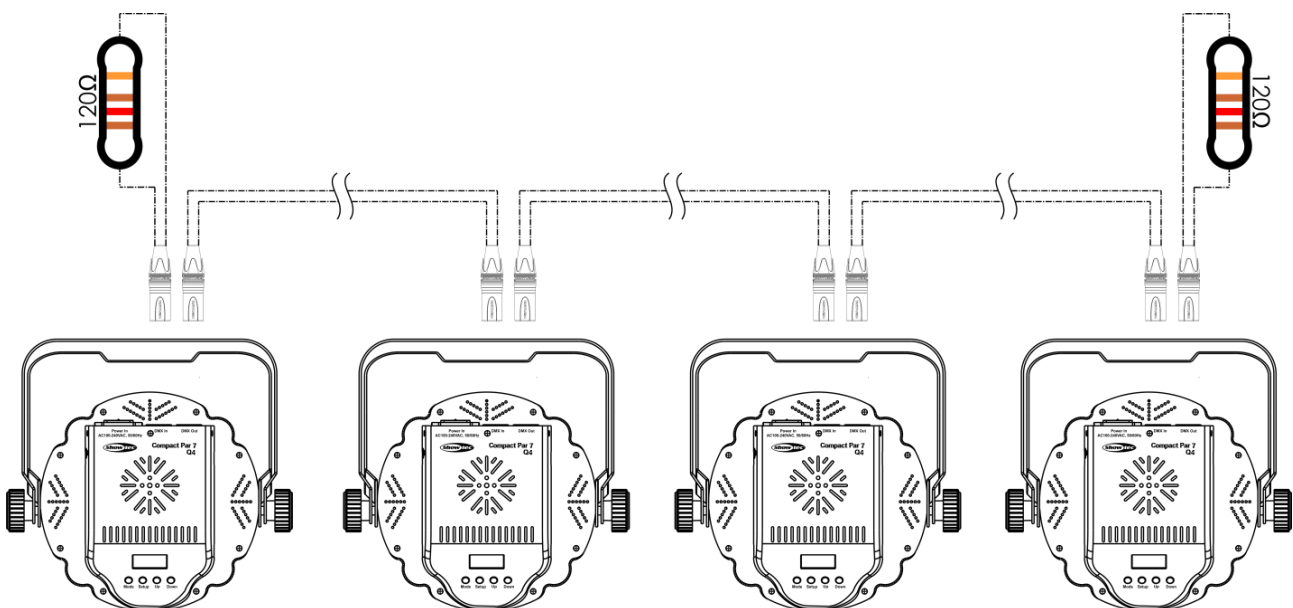
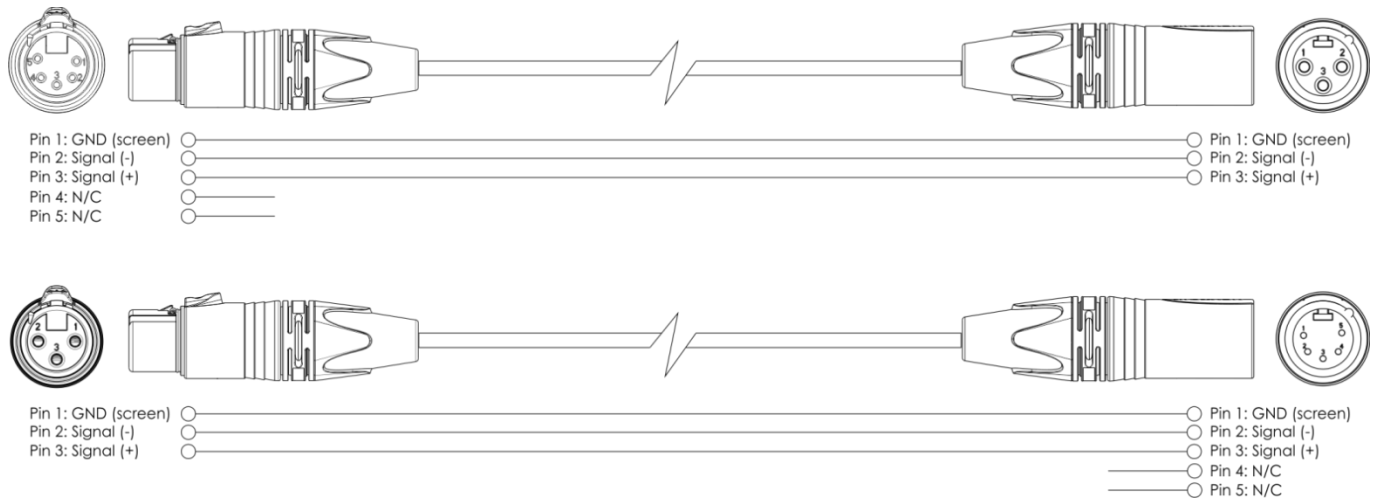

Fig. 03

Multiple Compact Pars 7 Q4 (DMX Control)

- 01) Fasten the effect light to a firm trussing. Leave at least 0,5 meter on all sides for air circulation.
- 02) Always use a safety cable (ordercode 70140 / 70141).
- 03) Use a 3-pin XLR cable to connect the Compact Pars and other devices.



- 04) Link the units as shown in Fig. 04. Connect the first unit's DMX "out" socket with the second unit's "in" socket, using a DMX-signal cable. Repeat this process to link the second, third, and fourth units.
- 05) Supply electric power: Plug electric mains power cords into each unit's IEC socket, then plug the other end of the mains power cord into proper electric power supply sockets, starting with the first unit. Do not supply power before the whole system is set up and connected properly.

Multiple Compact Pars 7 Q4 DMX Set Up

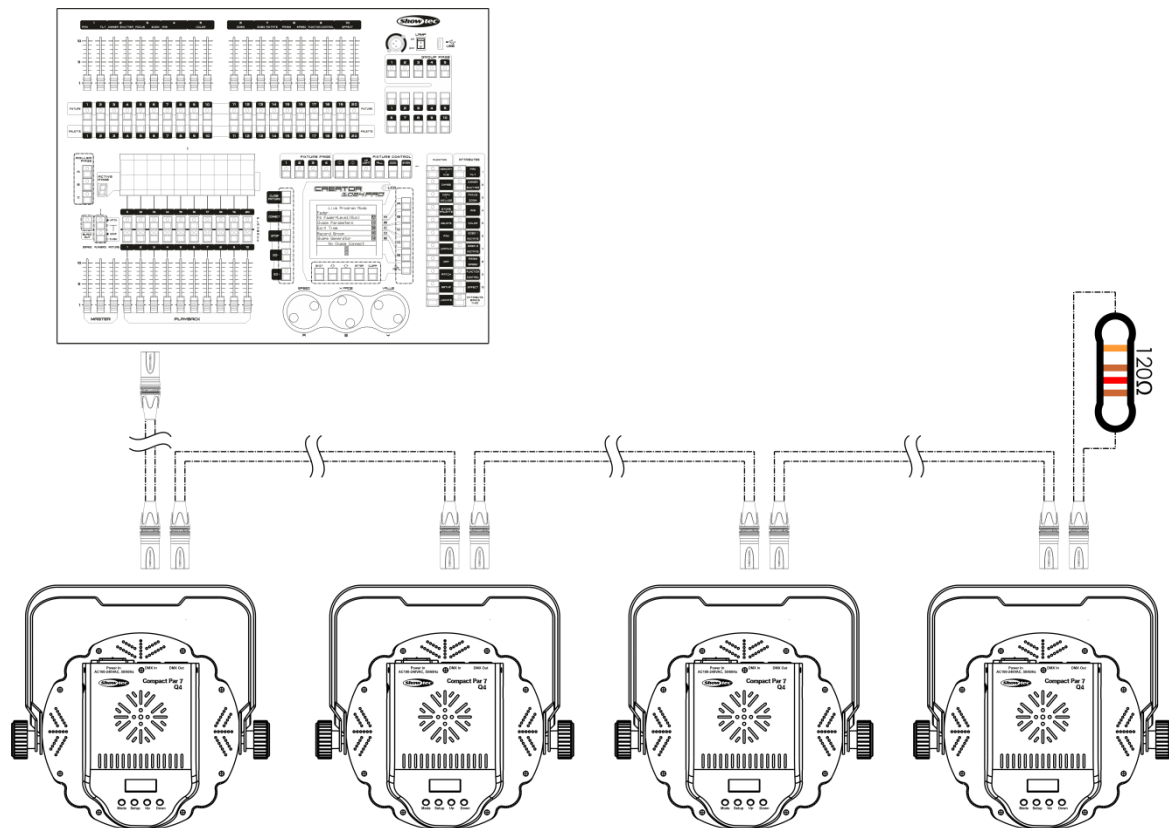

Note : Link all cables before connecting electric power

Fig. 04

Fixture Linking

You will need a serial data link to run light shows of one or more fixtures using a DMX-512 controller or to run synchronized shows of two or more fixtures set to a master/slave operating mode. The combined number of channels required by all the fixtures on a serial data link determines the number of fixtures the data link can support.

Important: Fixtures on a serial data link must be daisy-chained in a single line. To comply with the EIA-485 standard, no more than 30 devices should be connected on one data link. Connecting more than 30 fixtures on one serial data link without the use of a DMX optically isolated splitter may result in deterioration of the digital DMX signal.
Maximum recommended DMX data link distance: 100 meters
Maximum recommended number of fixtures on a DMX data link: 30 fixtures



Data Cabling

To link fixtures together, you must obtain data cables. You can purchase DAP Audio certified DMX cables directly from a dealer/distributor or construct your own cable. If you choose to create your own cable, please use data-grade cables that can carry a high quality signal and are less prone to electromagnetic interference.

DAP Audio DMX Data Cables

- DAP Audio Basic microphone cable for allround use. bal. XLR/M 3-pin > XLR/F 3-pin. **Ordercode** FL01150 (1,5 m), FL013 (3 m), FL016 (6 m), FL0110 (10 m), FL0115 (15 m), FL0120 (20 m).
- DAP Audio X-type data cable XLR/M 3-pin > XLR/F 3-pin. **Ordercode** FLX0175 (0,75 m), FLX01150 (1,5 m), FLX013 (3 m), FLX016 (6 m), FLX0110 (10 m).
- DAP Audio cable for the demanding user with exceptional audio-qualities and connector made by Neutrik®. **Ordercode** FL71150 (1,5 m), FL713 (3 m), FL716 (6 m), FL7110 (10 m).
- DAP Audio cable for the demanding user with exceptional audio-qualities and connector made by Neutrik®. **Ordercode** FL7275 (0,75 m), FL72150 (1,5 m), FL723 (3 m), FL726 (6 m), FL7210 (10 m).
- DAP Audio 110 Ohm cable with digital signal transmission. **Ordercode** FL0975 (0,75 m), FL09150 (1,5 m), FL093 (3 m), FL096 (6 m), FL0910 (10 m), FL0915 (15 m), FL0920 (20 m).
- DAP Audio DMX adapter: 3-pin/5-pin. **Ordercode** FLA30.

The Compact Par 7 Q4 can be operated with a controller in DMX mode or without the controller in stand-alone mode.

Control Panel

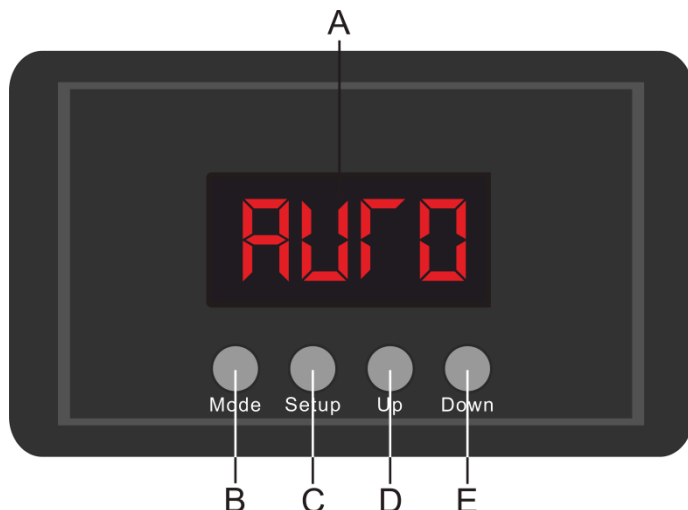

- A) LED display
- B) Mode button
- C) Setup button
- D) Up button
- E) Down button

Fig. 05

Control Mode

The fixtures are individually addressed on a data-link and connected to the controller.

The fixtures respond to the DMX signal from the controller. (When you select the DMX address and save it, the controller will display the saved DMX address, next time.)

DMX Addressing

The control panel on the back side of the device allows you to assign DMX fixture addresses, which is the first channel with which the Compact Par will respond to the controller.

Please note, when you use the controller, the unit has **11** channels.

When using multiple Compact Pars, make sure you set the DMX addresses right.

Therefore, the DMX address of the first Compact Par should be **1(001)**; the DMX address of the second Compact Par should be **1+11=12 (012)**; the DMX address of the third Compact Par should be **12+11=23 (023)**, etc. Please, be sure that you do not have any overlapping channels in order to control each Compact Par correctly. If two or more Compact Pars are addressed similarly, they will work similarly.

Controlling:

After having addressed all Compact Par fixtures, you may now start operating these via your lighting controller.

Note: After switching on, the Compact Par will automatically detect whether DMX 512 data is received or not. If there is no data received at the DMX-input, the "LED " on the control panel will not flash.

If not, the problem may be:

- The XLR cable from the controller is not connected with the input of the Compact Par.
- The controller is switched off or defective, the cable or connector is defective, or the signal wires are swapped in the input connector.

Note: It is necessary to insert an XLR termination plug (with 120 Ohm) in the last fixture in order to ensure proper transmission on the DMX data link.

Display Off after 20 seconds

When no button is pressed for 20 seconds, the display will turn off.

To light up the display, you have to press the **Mode**, **Setup**, **Up** or **Down** button.

Once you have pressed the button, the display will light up.

Menu Overview

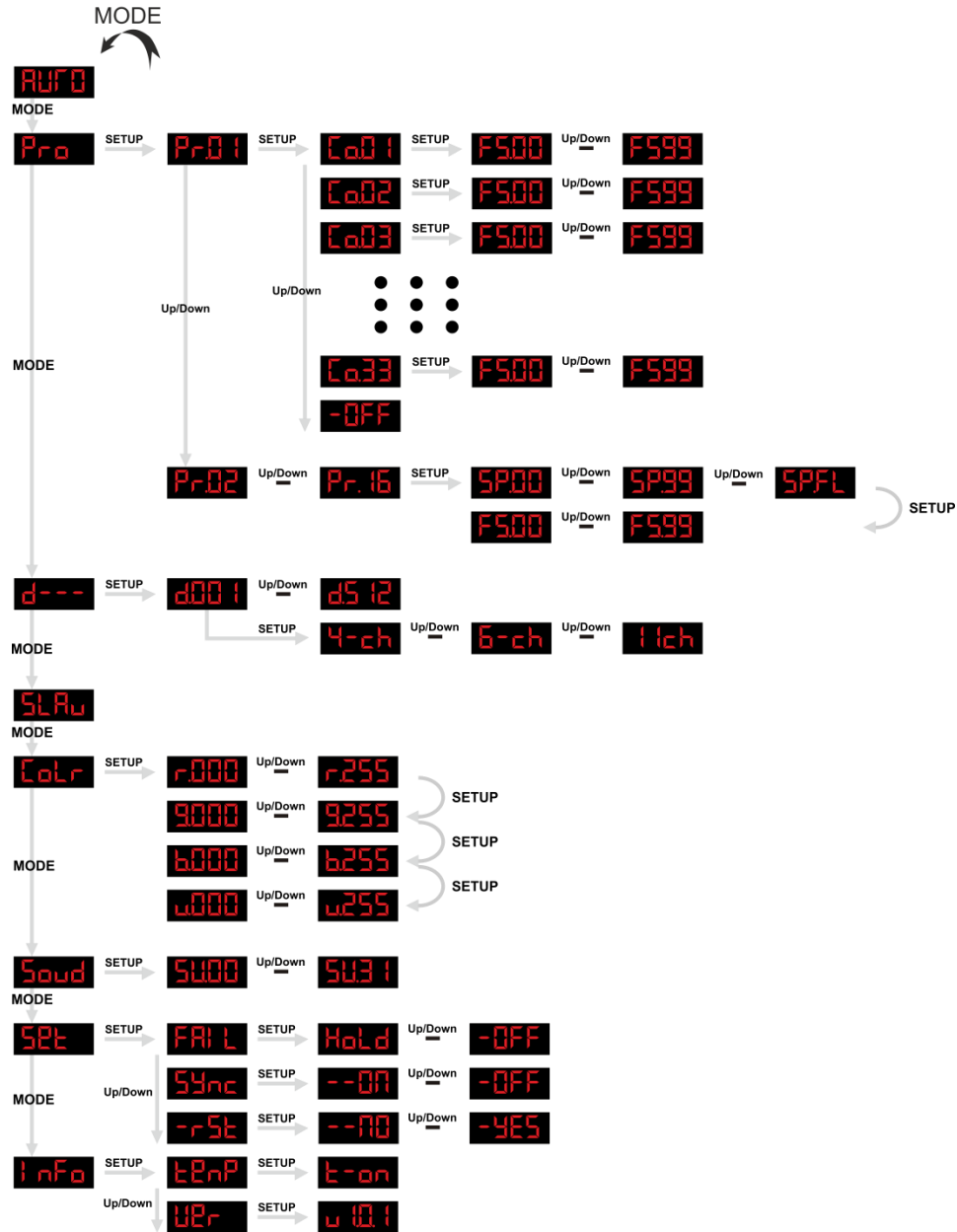

Main Menu Options

- AUFD** Auto run
- Pro** Built in programs
- d---** DMX address / DMX configuration
- SLAu** Master-Slave
- Colr** Static Color Mode
- Sound** Sound-controlled Mode
- SEt** Settings
- InFa** Info

Auto Run Mode

With this menu you can start the Auto Run program of the Compact Par 7 Q4.

- 01) Press the **Mode** button and then the **Up/Down** buttons, until the display shows **AUTO**.
- 02) The Compact Par will start immediately the Auto Run program.

Built-in Programs

With this menu you can set the built-in programs.

- 01) Press the **Mode** button and then the **Up/Down** buttons, until the display shows **Pro**.
- 02) Press the **Setup** button to open this menu.
- 03) You can use the **Up/Down** buttons to scroll through the 16 built-in programs.
- 04) When you select menu **Pr01**, you can use a wide variety (33) of manual color settings. Press **Setup** to enter and choose one with the **Up/Down** buttons.

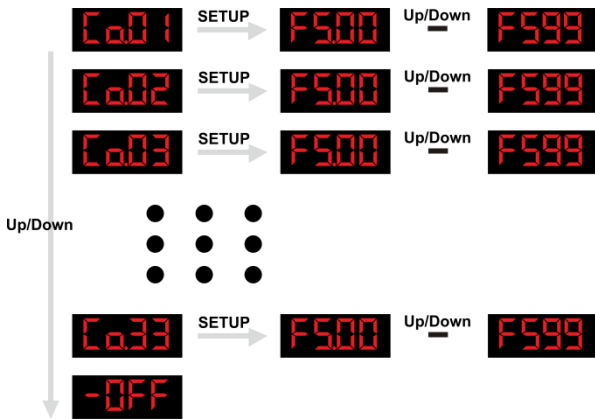

- 05) Press the **Setup** button to open menu **F500** **Up/Down** **F599**. You can set the Flash frequency with the **Up/Down** buttons.
- 06) Press the **Setup** button again, until the display shows **Pr01**.
- 07) Use the **Up/Down** buttons until the display shows **Pr02**.
- 08) Use the **Up/Down** buttons to scroll between **Pr02** **Up/Down** **Pr16**. In menu **Pr02** **Up/Down** **Pr16**, you can switch between the Flash frequency and the Program Running Speed by pressing the **Setup** button.
- 09) Use the **Up/Down** buttons to change the values.



DMX Addressing/ DMX configuration

With this menu you can set the DMX address and choose a DMX configuration.

- 01) Press the **Mode** button and then the **Up/Down** buttons, until the display shows **d--**.
- 02) Press the **Setup** button to open this menu. You can choose 512 different DMX addresses.
- 03) Use the **Up/Down** buttons to select the required address from **d001** **Up/Down** **d512**.
Once you have set the desired DMX address, you can also choose the desired DMX Mode.
- 04) Press the **Setup** button to choose one of the 3 different DMX Modes. Use the **Up/Down** buttons to select 4, 6 or 11 channels DMX mode.



Slave Mode

With this menu you can set the device as a Master or Slave.

- 01) Press the **Mode** button and then the **Up/Down** buttons, until the display shows **SLAV**.
If the device has not been set to slave, it is automatically classified as a master device. All slave devices will follow the master movement. If the device has been set to slave, it will react the same as its master device.

Static Color control

With this menu you can manually set a desired color.

- 01) Press the **Mode** button and then the **Up/Down** buttons, until the display shows **Colr**.
- 02) Press the **Setup** button to open this menu.
- 03) You can use the **Setup** button to scroll through the 4 color options.
- 04) Use the **Up/Down** buttons to change the values.

r000 Up/Down **r255** Gradual adjustment red (0-255)

g000 Up/Down **g255** Gradual adjustment green (0-255)

b000 Up/Down **b255** Gradual adjustment blue (0-255)

w000 Up/Down **w255** Gradual adjustment white (0-255)

You can combine Red, Green, Blue and White to create an infinite range of colors (0-255).

Sound control mode

With this menu you can set the sensitivity of the sound mode.

- 01) Press the **Mode** button and then the **Up/Down** buttons, until the display shows **Sound**.
- 02) Press the **Setup** button to open this menu.
- 03) Use the **Up/Down** buttons to change the values.
- 04) Set the sensitivity of the sound control mode between **s100** Up/Down **s131**.

Settings

With this menu you can set various options.

- 01) Press the **Mode** button and then the **Up/Down** buttons, until the display shows **SEt**.
- 02) Press the **Setup** button to open this menu.
- 03) Use the **Up/Down** buttons to choose between the 3 options, **FAiL**, **SYnc** and **r5t**.
- 04) Press the **Setup** button to open one of the 3 options.
- 05) With the **Up/Down** buttons you can set the desired option.
- 06) With option **FAiL** you can set the fixture to "HOLD" or "OFF". If you choose "OFF", the fixture will go out if there is no DMX signal. If you choose "HOLD", the fixture will remember the last settings and will not go out if there is no DMX signal.
- 07) The **SYnc** option is a tool which helps to keep multiple fixtures synchronized when using them in master slave mode.
- 08) With option **r5t** you can reset the device to the factory settings. If you choose "Yes" the fixture will reset and start up in the Auto Run mode.

Info

With this menu you can see various info of the fixture.

- 01) Press the **Mode** button and then the **Up/Down** buttons, until the display shows **INfo**.
- 02) Press the **Setup** button to open this menu.
- 03) Use the **Up/Down** buttons to choose between the 2 options, **tErP** and **UPr**.
- 04) Press the **Setup** button to see one of the 2 options.
- 05) With the option **tErP** you can see if the fixture is too hot or not. If the fixture has a normal temperature, the display will show "t-on". If the fixture is too hot, the display will show "t-nn". You'll have to switch off the fixture.
- 06) The option **UPr** is for showing the software version of the fixture.

DMX Channels**4 channels****Channel 1 – Red Dimmer intensity**

0-255 Red from 0-100%

Channel 2 – Green Dimmer intensity

0-255 Green from 0-100%

Channel 3 – Blue Dimmer intensity

0-255 Blue from 0-100%

Channel 4 – White Dimmer intensity

0-255 White from 0-100%

6 channels**Channel 1 – Master Dimmer intensity**

0-255 From dark to brightest 0-100%

Channel 2 – Linear strobe (CH1, CH3, CH4, CH5 or CH6 must be set between 001-255 )

0-10 Closed

11-255 Strobe flash frequency, from slow to fast (0-20 Hz)

Channel 3 – Red Dimmer intensity (CH1 must be set between 001-255 )

0-255 Red from 0-100%

Channel 4 – Green Dimmer intensity (CH1 must be set between 001-255 )

0-255 Green from 0-100%

Channel 5 – Blue Dimmer intensity (CH1 must be set between 001-255 )

0-255 Blue from 0-100%

Channel 6 – White Dimmer intensity (CH1 must be set between 001-255 )

0-255 White from 0-100%

11 channels**Channel 1 – Master Dimmer intensity**

0-255 From dark to brightest 0-100%

Channel 2 – Linear strobe (CH1, CH4, CH8, CH9, CH10 or CH11 must be set between 001-255 )

0-10 Closed

11-255 Strobe flash frequency, from slow to fast (0-20 Hz)

Channel 3 – Random strobe (CH1, CH4, CH8, CH9, CH10 or CH11 must be set between 001-255 )

0-10 Closed

11-255 Random strobe flash

Channel 4 – Color presets (CH1 must be set between 001-255 )

0-7	No function
8-13	Color 1 (R255, G000, B000, W000)
14-20	Color 2 (R255, G000, B000, W100)
21-27	Color 3 (R255, G000, B000, W200)
28-34	Color 4 (R255, G050, B000, W000)
35-41	Color 5 (R255, G150, B000, W000)
42-48	Color 6 (R255, G255, B000, W000)
49-55	Color 7 (R255, G255, B000, W075)
56-62	Color 8 (R255, G255, B000, W255)
63-69	Color 9 (R000, G255, B000, W150)
70-76	Color 10 (R000, G255, B000, W050)
77-83	Color 11 (R000, G255, B000, W000)
84-90	Color 12 (R000, G255, B050, W000)
91-97	Color 13 (R000, G255, B150, W000)
98-104	Color 14 (R000, G255, B255, W000)
105-111	Color 15 (R000, G255, B255, W075)
112-118	Color 16 (R000, G255, B255, W150)
119-125	Color 17 (R000, G100, B255, W255)
126-132	Color 18 (R000, G000, B255, W100)
133-139	Color 19 (R000, G000, B255, W050)
140-146	Color 20 (R000, G000, B255, W000)
147-153	Color 21 (R075, G000, B255, W000)
154-160	Color 22 (R160, G000, B255, W000)
161-167	Color 23 (R255, G000, B255, W000)
168-174	Color 24 (R255, G000, B175, W000)
175-181	Color 25 (R255, G000, B100, W000)
182-188	Color 26 (R255, G000, B100, W050)
189-195	Color 27 (R255, G000, B025, W050)
196-202	Color 28 (R255, G000, B025, W025)
203-209	Color 29 (R255, G000, B025, W000)
210-216	Color 30 (R000, G000, B000, W255)
217-223	Color 31 (R075, G075, B000, W255)
224-230	Color 32 (R000, G000, B100, W255)
231-255	Color 33 (R255, G255, B255, W255)

Channel 5 – Color running (CH1 must be set between 001-255 and CH6 between 0-255 )

0-15	No function
16-31	Jump 1
32-47	Jump 2
48-63	Jump 3
64-79	Jump 4
80-95	Jump 5
96-111	Jump 6
112-127	Jump 7
128-143	Jump 8
144-159	Fade 1
160-175	Fade 2
176-191	Fade 3
192-207	Fade 4
208-223	Fade 5
224-239	Fade 6
240-255	Fade 7

Channel 6 – Speed color running

0-255 Gradual speed adjustment, from slow to fast

Channel 7 – Sound mode

0-50 No function

51-255 Gradual adjustment Sensitivity, from 1-100%

Channel 8 – Red Dimmer intensity (CH1 must be set between 001-255)

0-255 Red from 0-100%

Channel 9 – Green Dimmer intensity (CH1 must be set between 001-255)

0-255 Green from 0-100%

Channel 10 – Blue Dimmer intensity (CH1 must be set between 001-255)

0-255 Blue from 0-100%

Channel 11 – White Dimmer intensity (CH1 must be set between 001-255)

0-255 White from 0-100%

Maintenance

The operator has to make sure that safety-related and machine-technical installations are to be inspected by an expert after every year in the course of an acceptance test.

The operator has to make sure that safety-related and machine-technical installations are to be inspected by a skilled person once a year.

The following points have to be considered during the inspection:

- 01) All screws used for installing the device or parts of the device have to be tightly connected and must not be corroded.
- 02) There may not be any deformations on housings, fixations and installation spots.
- 03) Mechanically moving parts like axles, eyes and others may not show any traces of wearing.
- 04) The electric power supply cables must not show any damages or material fatigue.

The Compact Par 7 Q4 requires almost no maintenance. However, you should keep the unit clean. Otherwise, the fixture's light-output will be significantly reduced. Disconnect the mains power supply, and then wipe the cover with a damp cloth. Do not immerse in liquid. Wipe lens clean with glass cleaner and a soft cloth. Do not use alcohol or solvents.

The front lens will require weekly cleaning, as smoke-fluid tends to build up residues, reducing the light-output very quickly.

Keep connections clean. Disconnect electric power, and then wipe the DMX and audio connections with a damp cloth. Make sure connections are thoroughly dry before linking equipment or supplying electric power.

Replacing the Fuse

Power surges, short-circuit or inappropriate electrical power supply may cause a fuse to burn out.

If the fuse burns out, the product will not function whatsoever. If this happens, follow the directions below:

- 01) Unplug the unit from electric power source.
- 02) Insert a flat-headed screwdriver into a slot in the fuse cover. Gently pry up the fuse cover. The fuse will come out.
- 03) Remove the used fuse. If brown or unclear, it is burned out.
- 04) Insert the replacement fuse into the holder. Reinsert the fuse cover. Be sure to use a fuse of the same type and specification. See the product specification label for details.

Troubleshooting

This troubleshooting guide is meant to help solve simple problems.

If a problem occurs, carry out the steps below in sequence until a solution is found. Once the unit operates properly, do not carry out following steps.

No Light

If the light effect does not operate properly, refer servicing to a technician.

Suspect three potential problem areas as: the power supply, the LEDs, the fuse.

- 01) Power supply. Check that the unit is plugged into an appropriate power supply.
- 02) The LEDs. Return the Compact Par to your Showtec dealer.
- 03) The fuse. Replace the fuse. See page 19 for replacing the fuse.
- 04) If all of the above appears to be O.K., plug the unit in again.
- 05) If you are unable to determine the cause of the problem, do not open the Compact Par, as this may damage the unit and the warranty will become void.
- 06) Return the device to your Showtec dealer.

No Response to DMX

Suspect the DMX cable or connectors, a controller malfunction, a light effect DMX card malfunction.

- 01) Check the DMX setting. Make sure that DMX addresses are correct.
- 02) Check the DMX cable: Unplug the unit; change the DMX cable; then reconnect to electrical power. Try your DMX control again.
- 03) Determine whether the controller or light effect is at fault. Does the controller operate properly with other DMX products? If not, take the controller in for repair. If so, take the DMX cable and the light effect to a qualified technician.

Problem	Probable cause(s)	Solution
One or more fixtures do not function at all	No power to the fixture	<ul style="list-style-type: none"> • Check if power is switched on and cables are plugged in
	Primary fuse blown	<ul style="list-style-type: none"> • Replace fuse
Fixtures reset correctly, but all respond erratically or not at all to the controller	The controller is not connected	<ul style="list-style-type: none"> • Connect controller
	3-pin DMX OUT of the controller does not match DMX IN of the first fixture on the link (i.e. signal is reversed)	<ul style="list-style-type: none"> • Install a phase reversing cable between the controller and the first fixture on the link
Fixtures reset correctly, but some respond erratically or not at all to the controller	Poor data quality	<ul style="list-style-type: none"> • Check data quality. If much lower than 100 percent, the problem may be a bad data link connection, poor quality or broken cables, missing termination plug, or a defective fixture disturbing the link
	Bad data link connection	<ul style="list-style-type: none"> • Inspect connections and cables. Correct poor connections. Repair or replace damaged cables
	Data link not terminated with 120 Ohm termination plug	<ul style="list-style-type: none"> • Insert termination plug in the DMX OUT connector of the last fixture on the link
	Incorrect addressing of the fixtures	<ul style="list-style-type: none"> • Check address settings
	One of the fixtures is defective and disturbs data transmission on the link	<ul style="list-style-type: none"> • Bypass one fixture at a time until normal operation is restored: unplug both connectors and connect them directly together • Have the defective fixture serviced by a qualified technician
	3-pin DMX OUT on the fixtures does not match (pins 2 and 3 reversed)	<ul style="list-style-type: none"> • Install a phase-reversing cable between the fixtures or swap pin 2 and 3 in the fixture that behaves erratically
No light or LEDs cut out intermittently	Fixture is too hot	<ul style="list-style-type: none"> • Allow the fixture to cool down • Clean the fans • Make sure the cooling fans are not blocked • Turn up the air conditioning
	LEDs are damaged	<ul style="list-style-type: none"> • Disconnect the fixture and return it to your dealer
	The power supply settings do not match local AC voltage and frequency	<ul style="list-style-type: none"> • Disconnect fixture. Check settings and correct if necessary

Product Specifications

Model:	Showtec Compact Par 7 Q4
Input Voltage:	100-240 VAC, 50/60Hz
Power consumption:	32W (full output)
Drive Current:	330mA
Refresh rate	7,8 kHz
DMX linking:	30 pcs
Protection rate:	IP-20
Fuse:	T1L/250V
Dimensions:	272 x 92 x 260 mm (LxWxH)
Weight:	2,14 kg
Operating and Programming:	
Signal pin OUT:	Pin 1 (earth), pin 2 (-), pin 3 (+)
DMX Mode:	4, 6 or 11 channels
Signal input:	3-pin DMX IN
Signal output:	3-pin DMX OUT
Electro-mechanical effects:	
LED Quantity:	7 x 4W RGBW LED
Lux @2m:	2201
Color mixing:	RGBW
Beam angle:	18°
Dimmer:	0-100%
Strobe:	0-20Hz
Housing:	Aluminum and Iron
DMX-control:	via standard DMX-controller
On Board:	4-digit LED display for easy setup
Control:	Built-in Programs, Auto, Sound-controlled, Static color, Master/Slave, DMX
Connections:	IEC & 3-pin XLR IN & OUT
Cooling:	Aluminum heat sink
Max. ambient temperature t_a :	40°C
Max. housing temperature t_B :	80°C
Minimum distance:	
Minimum distance from flammable surfaces:	0,5 m
Minimum distance to lighted object:	1 m

Design and product specifications are subject to change without prior notice.



Website: www.Showtec.info
 Email: service@highlite.com

Dimensions

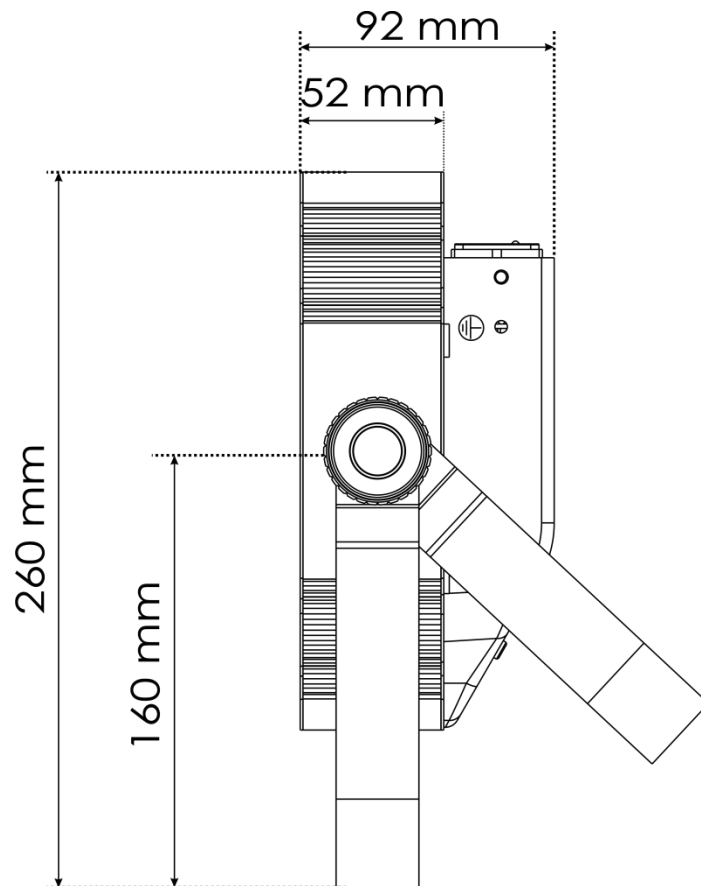
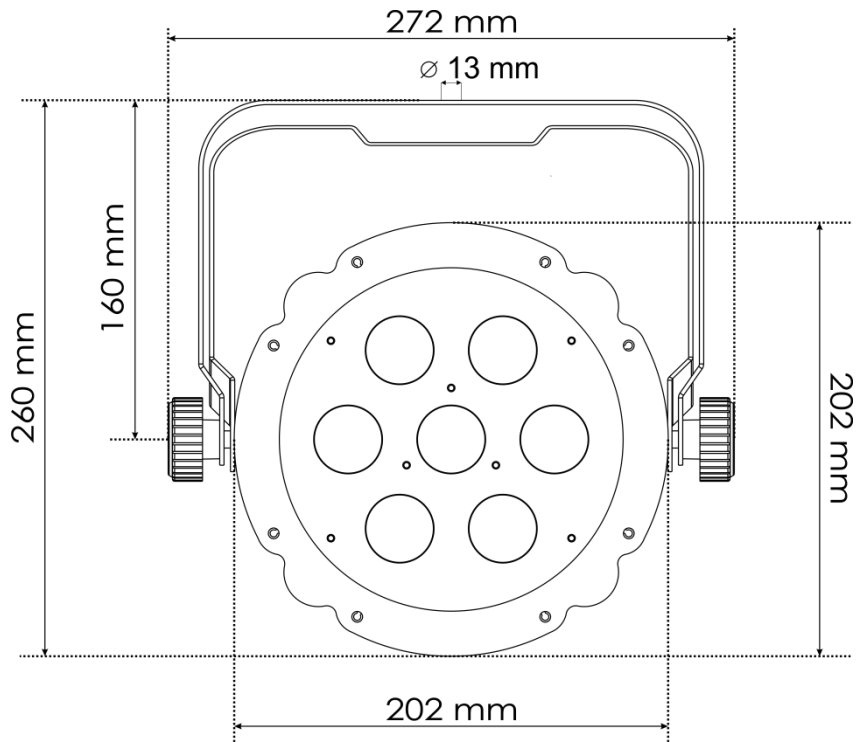



©2020 Showtec